

SO-PDS STEERING PRIORITY FLOW CONTROL VALVE WITH STATIC LOAD SENSE

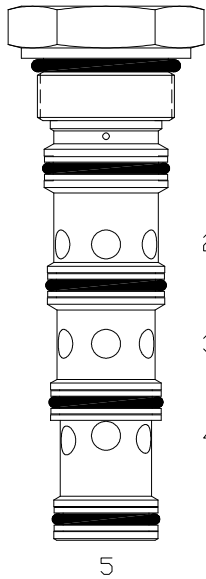

DESCRIPTION

16 size, 1 5/16-12 thread, "Super" series, steering priority flow control valve with static load sense.

OPERATION

The SO-PDS allows priority flow from (3) to (4) regardless of load pressure at either port (2) or port (4). Excess flow bypasses out (2). Port (1) is the load sense port.

FEATURES

- Hardened cage and spool for long life.
- Industry common cavity.

HYDRAULIC SYMBOL

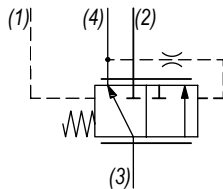

PERFORMANCE

Actual Test Data (Cartridge Only)

VALVE SPECIFICATIONS

Max Regulated Flow	20 GPM (76 LPM)
Rated Operating Pressure	3000 PSI (207 bar)
Viscosity Range	36 to 3000 SSU (3 to 647 cSt)
Filtration	ISO 18/16/13
Media Operating Temp. Range	-40° to 250°F (-40° to 120°C)
Weight	1.05 lbs (.48 kg)
Operating Fluid Media	General Purpose Hydraulic Fluid
Cartridge Torque Requirements	90 ft-lbs (122 Nm)
Cavity	SUPER 5WS
Cavity Form Tool (Finishing)	40500020
Seal Kit	21191410

Bypass port 2 loaded, priority port 4 unloaded

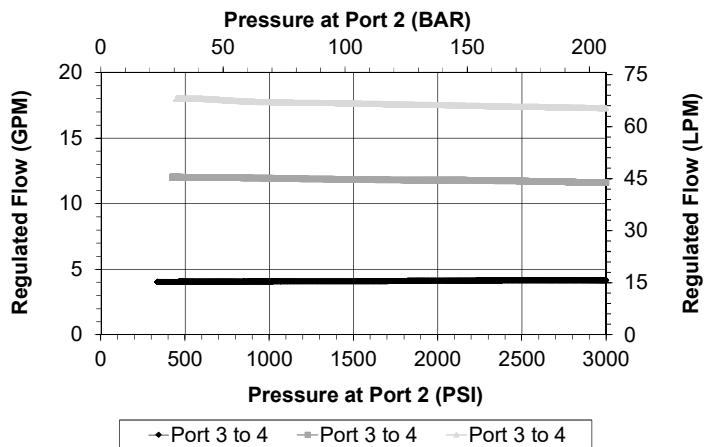

Priority port 4 loaded, bypass port 2 unloaded

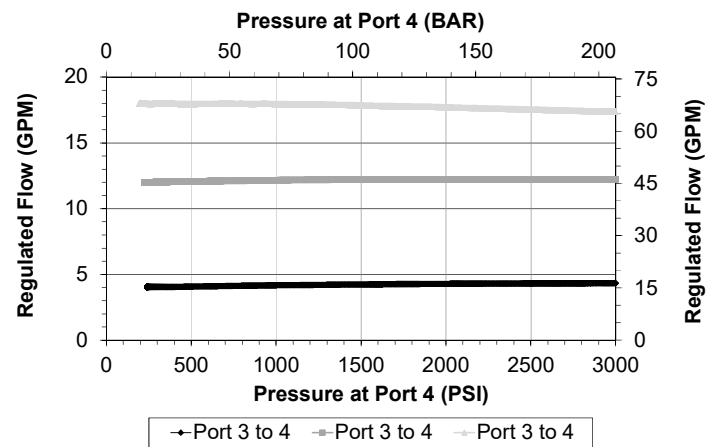

WARNING: the specifications/application data shown in our catalogs and data sheets are intended only as a general guide for the product described (herein). Any specific application should not be undertaken without independent study, evaluation, and testing for suitability.



4484 Boeing Drive Rockford, IL 61109 • USA • Phone +1 (815) 397-6628 • Fax +1 (815) 397-2526
 mail: delta@delta-power.com • www.delta-power.com



Via Malavolti, 36 • 41122 Modena • ITALY • Phone +39 (059) 254895 • Fax +39 (059) 253512
 mail: tecnord@tecnord.com • www.tecnord.com

DIMENSIONS

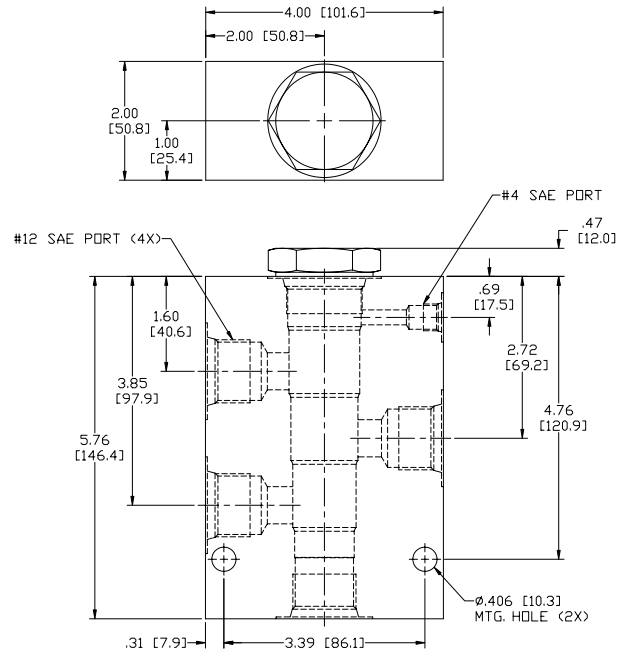
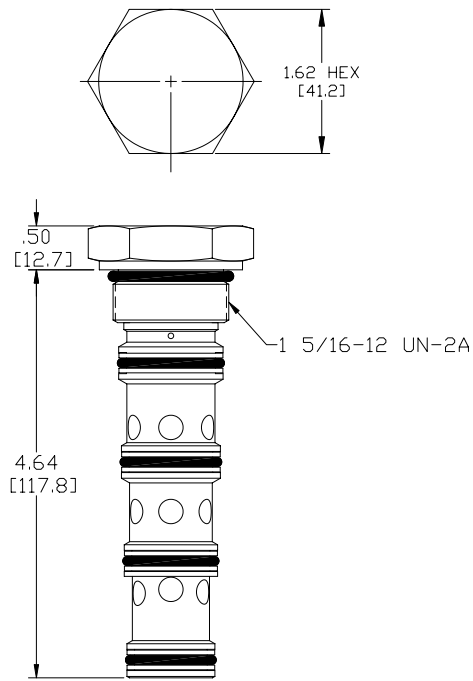

Body Weight: 3.76 lbs (1.62 kg)

ORDERING INFORMATION

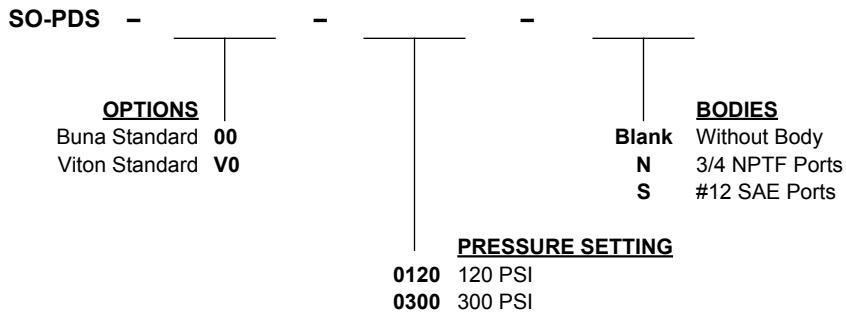

W 6 / 2020

WARNING: the specifications/application data shown in our catalogs and data sheets are intended only as a general guide for the product described (herein). Any specific application should not be undertaken without independent study, evaluation, and testing for suitability.



4484 Boeing Drive Rockford, IL 61109 • USA • Phone +1 (815) 397-6628 • Fax +1 (815) 397-2526
 mail: delta@delta-power.com • www.delta-power.com



Via Malavolti, 36 • 41122 Modena • ITALY • Phone +39 (059) 254895 • Fax +39 (059) 253512
 mail: tecnord@tecnord.com • www.tecnord.com