

DE-PSD PRESSURE SHUT DOWN VALVE

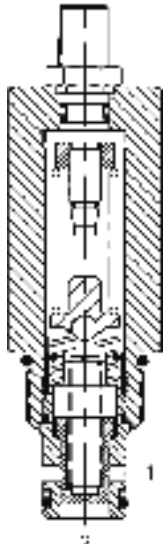

DESCRIPTION

10 size, 7/8-14 thread, "Delta" series, pressure shut down valve.

OPERATION

The DE-PSD blocks flow from (2) to (1) until sufficient pressure is present at (2) to open the pilot, thereby forcing the spool to open and allowing flow from (2) to (1). The valve stays open until the differential pressure from (2) to (1) decreases to less than 50 PSI (3.4 bar).

FEATURES

- Hardened parts for long life.
- Industry common cavity.

HYDRAULIC SYMBOL

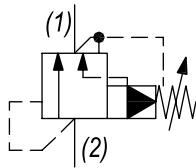

Usually the valve requires flow to be reduced to near zero before the valve will reset.

PERFORMANCE

Actual Test Data (Cartridge Only)

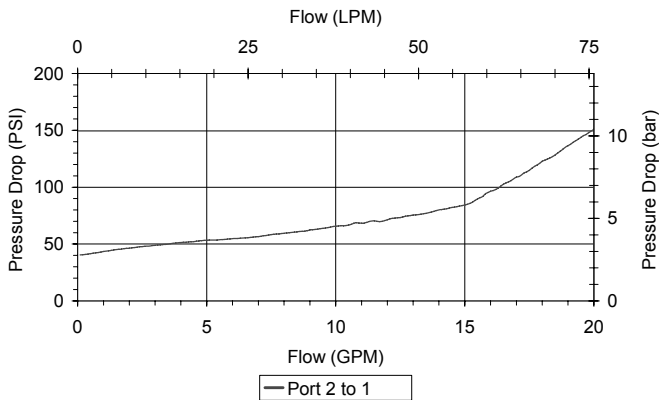

VALVE SPECIFICATIONS

Nominal Flow	15 GPM (57 LPM)
Rated Operating Pressure	4500 PSI (310 bar)
Viscosity Range	36 to 3000 SSU (3 to 647 cSt)
Filtration	ISO 18/16/13
Media Operating Temp. Range	-40° to 250°F (-40° to 120°C)
Weight	.53 lbs (.24 kg)
Operating Fluid Media	General Purpose Hydraulic Fluid
Cartridge Torque Requirements	30 ft-lbs (40.6 Nm)
Cavity	DELTA 2W
Cavity Form Tool (Finishing)	40500000
Seal Kit	21191200

WARNING: the specifications/application data shown in our catalogs and data sheets are intended only as a general guide for the product described (herein). Any specific application should not be undertaken without independent study, evaluation, and testing for suitability.



4484 Boeing Drive Rockford, IL 61109 • USA • Phone +1 (815) 397-6628 • Fax +1 (815) 397-2526
 mail: delta@delta-power.com • www.delta-power.com



Via Malavolti, 36 • 41122 Modena • ITALY • Phone +39 (059) 254895 • Fax +39 (059) 253512
 mail: tecnord@tecnord.com • www.tecnord.com

DIMENSIONS

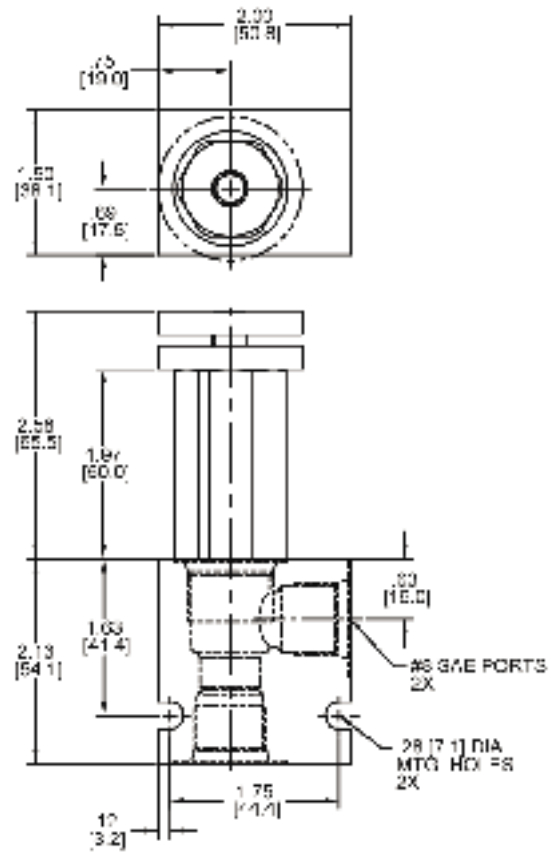
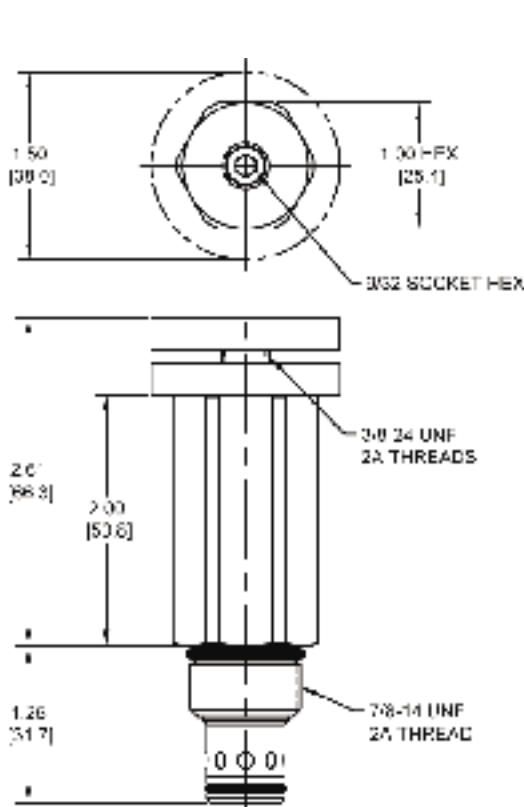

Body Weight: .47 lbs (.21 kg)

ORDERING INFORMATION

DE-PSD	-	-	-	-
OPTIONS				BODIES
Buna Standard				Blank
Viton Standard	00			N 3/8" NPTF Ports
Buna, Knob	V0			S #8 SAE Ports
Viton, Knob	0K			
Buna, Internal Adjust	0I			
Viton, Internal Adjust	VI			
Buna, Tamper Proof	0T			
Viton, Tamper Proof	VT			
			PRESSURE RANGE/SETTING	
			3000 100-3000 PSI	
			4500 3000-4500 PSI	

Tamper Proof
Fill in 4 Digit Pressure Setting
Example: 0500 = 500 PSI

Note: aluminum NOT durability rated for 4000 PSI. Consult factory for options.

W 6 / 2020

WARNING: the specifications/application data shown in our catalogs and data sheets are intended only as a general guide for the product described (herein). Any specific application should not be undertaken without independent study, evaluation, and testing for suitability.



4484 Boeing Drive Rockford, IL 61109 • USA • Phone +1 (815) 397-6628 • Fax +1 (815) 397-2526
mail: delta@delta-power.com • www.delta-power.com



Via Malavolti, 36 • 41122 Modena • ITALY • Phone +39 (059) 254895 • Fax +39 (059) 253512
mail: tecnord@tecnord.com • www.tecnord.com