

IP-DAR-250 DIRECT ACTING PROPORTIONAL, PRESSURE REDUCING/RELIEVING, SLIP-IN TYPE

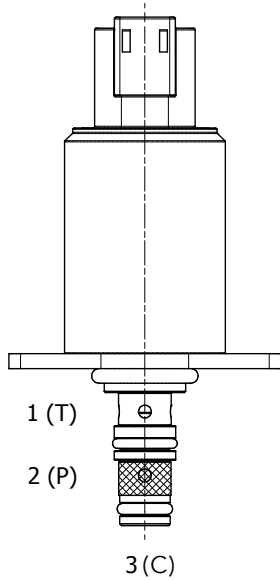

DESCRIPTION

Special cavity, slip-in style flange retained, direct acting proportional, pressure reducing/relieving valve.

OPERATION

The IP-DAR-250 generates a variable pressure in response to a PWM (Pulse Width Modulated) current signal. With no current applied to the proportional solenoid, the inlet port 2 (P) is blocked and the regulated port 3 (C) is vented to port 1 (T). As current is increased, fluid pressure is proportionally controlled at the regulated port 3 (C). On attainment of proportionally determined pressure at 3 (C), the cartridge shifts to block flow at 2 (P), thereby regulating pressure at 3 (C). In this mode, the valve also will relieve 3 (C) to 1 (T) at a variable value over the set reducing pressure.

FEATURES

- Slip-in style.
- Efficient wet-armature construction.
- Integral waterproof coil.
- Continuous duty rated solenoid.



Flanged retained product. The coil is an integral part of the valve and is not serviceable. Eventual tank pressure exceeding 0 bar, has to be added to reduced pressure value.

HYDRAULIC SYMBOL

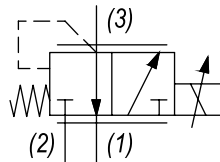

PERFORMANCE

Pressure Vs. Current Characteristic

Oil viscosit 46 cSt @ 45°C

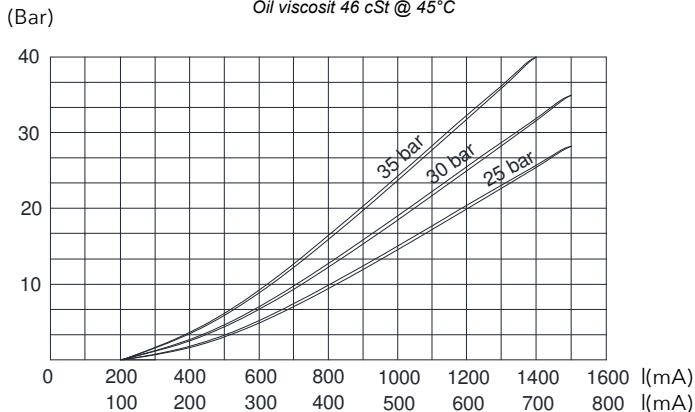

VALVE SPECIFICATIONS

Nominal Flow	1 GPM (4 LPM) @ 8 bar Delta P
Max Inlet Pressure "L" version	700 PSI (50 bar)
Controlled Pressure Range	0÷25 bar / 0÷30 bar / 0÷35 bar (see graph)
Reduced Pressure Tolerance	±5%
Max Back-Pressure at T Port	30 bar
Internal Leakage	15 ml/min @ 500 PSI (35 bar) inlet
Viscosity Range	36 to 3000 SSU (3 to 647 cSt)
Filtration	ISO 18/15/13
Media Operating Temp. Range	-30°C / +100°C
Weight	.43 lbs (.20 kg)
Operating Fluid Media	General Purpose Hydraulic Fluid
Cavity	T250
Cavity Tool Kit	K-T250
Flange Mounting Screws and Torque	M4x10 / 3ft-lbs (4 Nm)

COIL SPECIFICATIONS

Current Supply Characteristics	PWM (Pulse Width Modulation)
Rated Current Range	200÷1500 (12 V coil) 100÷750 (24 V coil)
PWM or Super-Imposed Dither Freq.	100-200 Hz
Coil Resistance (12 VDC)	4.8 Ohm ±5% at 68°F (20°C)
(24 VDC)	20 Ohm ±5% at 68°F (20°C)
Max Power Consumption	11 Watt (20°C)
Coil Termination	Deutsch-Integral DT04-2P (DT) AMP Jr. Timer 84-9419 (AJ)
Color Connectors	Black
Protection Degree (according to IEC 529)	IP 69K (DT) IP 67 (AJ)

WARNING: the specifications/application data shown in our catalogs and data sheets are intended only as a general guide for the product described (herein). Any specific application should not be undertaken without independent study, evaluation, and testing for suitability.



4484 Boeing Drive Rockford, IL 61109 • USA • Phone +1 (815) 397-6628 • Fax +1 (815) 397-2526
mail: delta@delta-power.com • www.delta-power.com



Via Malavolti, 36 • 41122 Modena • ITALY • Phone +39 (059) 254895 • Fax +39 (059) 253152
mail: tecnord@tecnord.com • www.tecnord.com

DIMENSIONS

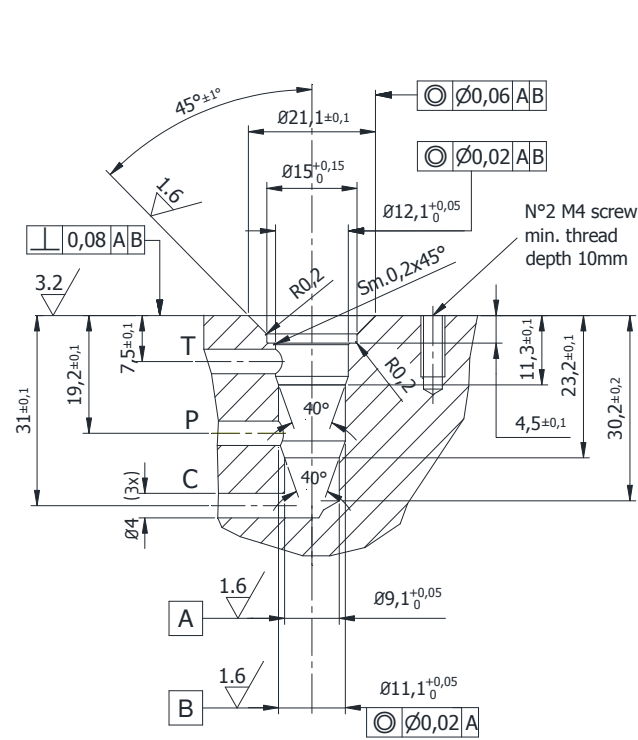
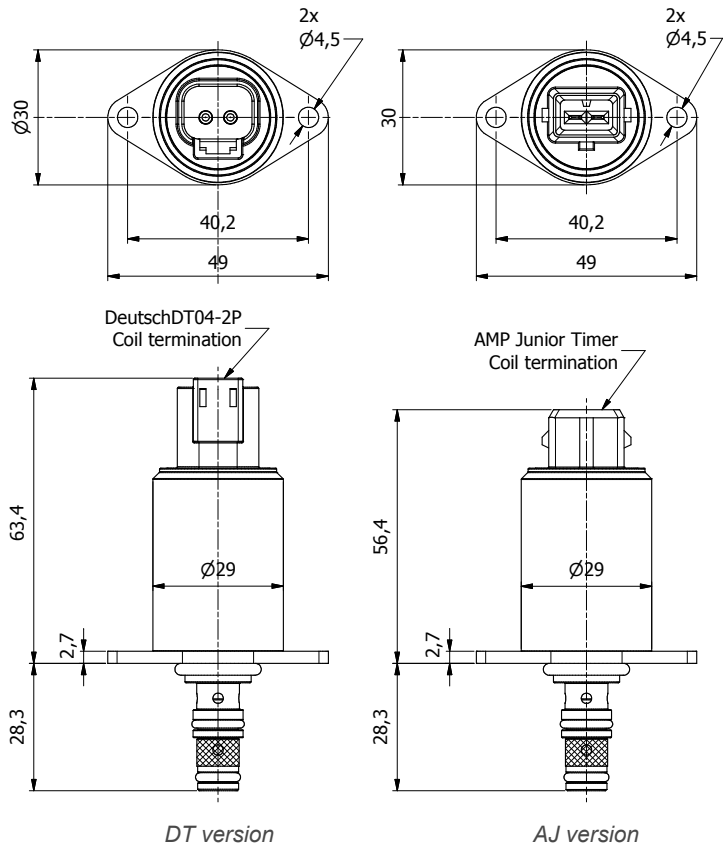

ORDERING INFORMATION

IP-DAR-250	COIL TERMINATION	VOLTAGE	INLET PRESSURE	MAX REGULATED PRESSURE	OPTIONS	BODIES
-	AJ - AMP Jr. Timer	12 VDC	L - up to 700 PSI (50 bar)	20 bar	AH - HNBR seals and 300 µm (50 mesh) screen on port 2	Blank - Without body
-	DT - Deutsch DT04	24 VDC		25 bar		N - 1/4" BSP Ports
-				32 bar		

W6 / 2020

WARNING: the specifications/application data shown in our catalogs and data sheets are intended only as a general guide for the product described (herein). Any specific application should not be undertaken without independent study, evaluation, and testing for suitability.



4484 Boeing Drive Rockford, IL 61109 • USA • Phone +1 (815) 397-6628 • Fax +1 (815) 397-2526
 mail: delta@delta-power.com • www.delta-power.com



Via Malavolti, 36 • 41122 Modena • ITALY • Phone +39 (059) 254895 • Fax +39 (059) 253512
 mail: tecnord@tecnord.com • www.tecnord.com